





Thank you for using E1000 series, economical AC motor speed controller made by TECORP ELECTRONIC CO., LTD

In order to make use of the functions full on the AC motor speed controller and ensure safety of user, please read this instruction carefully before installing, running, maintaining and checking AC motor speed controller.

This instruction divides safety cautions into Danger and Warning, please pay special attention to the symbols “ Danger” and “ Warning” and their related content.

The symbol “ Danger” indicates incorrect operation, which can cause death or serious injury to personnel.

The symbol “ Warning” indicates incorrect operation, which can cause personnel injury or AC motor speed controller and mechanical system fault, as determined by different situations, the caution affairs may lead to serious consequence.

The figures in this instruction are for convenience with descriptions; they may have slight differences compared to the products, and the products update can also cause slight differences between the figures and products, the actual sizes are subject to actual products.

Please notice that this operational instruction shall be delivered to the end user, and be kept appropriately for further use of inspecting and maintaining.

If you have questions, please contact us or our agents in time, you will always receive our best attention.

## Contents

<b>Chapter 1 Safety Cautions</b> -----	<b>2</b>
1-1 Confirmation on Receiving -----	2
1-2 Moving and Installation-----	2
1-3 Wiring and Junction -----	4
1-4 Power on and Commissioning-----	5
1-5 Check and Maintenance -----	6
1-6 Exception Processing -----	7
1-7 Scrapping Processing-----	7
<b>Chapter 2 Product Introduction</b> -----	<b>8</b>
2-1 Unpacking Inspection-----	8
2-2 Model Description -----	8
2-3 Product Specifications -----	9
2-4 Product Models-----	10
2-5 Dimensions-----	10
<b>Chapter 3 Wiring and Operation</b> -----	<b>11</b>
3-1 Wiring Diagram -----	11
3-2 Display Panel -----	11
3-3 Parameter Setting -----	12
<b>Chapter 4 Table of Functional Parameters</b> -----	<b>13</b>
<b>Chapter 5 Fault Alarm and Solutions</b> -----	<b>17</b>

# Chapter 1 Safety Cautions

## 1-1 Confirmation on Receiving

### ▲ Warning

All the products have gone by strictly checking and testing before delivery, but considering transportation, please verify:

- Whether AC motor speed controller is distorted or damaged during transportation, do not install broken AC motor speed controller, and it may cause personnel injury, please inform our agent in time.
- Whether the package is integrated, accessories and user's instruction are contained, especially the user's instruction and guarantee card, please keep those for reference of further maintenance
- Whether the product is in accordance with the specifications, and whether there are unusual phenomena inside or outside AC motor speed controller.

## 1-2 Moving and Installation

### ▲ Warning

- When moving the product, please use proper moving instruments to prevent AC motor speed controller from damage.
- When moving AC motor speed controller, please fasten the bottom of AC motor speed controller, holding the cover plate directly may lead to dropping and cause personnel injury or AC motor speed controller damaged.
- Please do not install AC motor speed controller on combustible substance, installing the convert directly on the combustible substance or near to combustible material may cause fire accident.
- Please verify whether installation of AC motor speed controller is correct.
- Please choose a safe location to install AC motor speed controller, and operation environment is shown as follows.

---

Ambient temperature:  $-10^{\circ}\text{C}$ - $40^{\circ}\text{C}$  (non-freezing) .

Ambient humidity: max. 95% relative humidity  
(non-condensing)

Ambient environment: indoors, (no corrosive gas, combustible gas, oil mist and dust. Please keep off sunlight) .

Altitude: lower than 1000m

Vibration: max. 0.5G

- Please make sure that the mounted substance can load with AC motor speed controller's weight and prevent it from falling, and make sure that the installation site is safe and reliable. Do not allow children and unauthorized personnel approaching AC motor speed controller.
- Please make sure that the screws are fixed, fastened and locked firmly in accordance with user's instruction of the manual, to prevent AC motor speed controller from falling.
- During installation, prevent screws, wire pieces and other electricity conductive material from falling in AC motor speed controller. Otherwise, AC motor speed controller may be damaged, or a serious accident may take place.
- If two and more AC motor speed controller is installed in one control cabinet, please install them according to the instruction of the manual. It is required to keep enough space, and add extra heat sinkers for airflow in the cabinet. That will lower  $40^{\circ}\text{C}$  of the temperature in the cabinet. Overheating may cause AC motor speed controller broken, fire or other accident.
- AC motor speed controller shall be installed by professional personnel.

## 1-3 Wiring and Junction

### ▲ Warning

- Please do not damage the wires. Let the wires bear weight or be clamped may damage the wires and cause an electric shock.
- Do not install the phase-shifting capacitor, surge absorber or noise filter in output terminal of AC motor speed controller, otherwise may cause AC motor speed controller fault.
- Do not install switch devices in the output terminal of AC motor speed controller such as the air switch and contactor. If it is for technologic demand, please ensure that AC motor speed controller is switching without output.
- Please wire separately power wire and control wire for preventing interference.

### ⚡ Danger

- Please ensure that the power is off before Junction.
- The wiring work shall be done by qualified electricians.
- Please wire in accordance with the user's instruction of the manual.
- The grounding connection shall be installed properly in accordance with relative regulations in the user's instruction. Otherwise it may cause an electric shock or fire.
- Please use independent power supply for AC motor speed controller. Never use the same power supply with strong interference equipment like electric welder.
- Please do not touch the bottom plate with wet hand. Otherwise you may get an electric shock.
- Please do not touch the terminal directly. Do not connect with AC motor speed controller input/output cables with the cover panel. Otherwise you may get an electric shock.
- Please make sure that voltage of the power supply and voltage of AC motor speed controller are the same, otherwise it may cause AC motor speed controller fault or personnel injury.
- Please make sure that power supply connects with the R·S·T terminal but without the U·V·W terminal, otherwise it may cause

- 
- the internal fault of AC motor speed controller.
- Please do not test AC motor speed controller on pressure resistance. Otherwise it may cause the internal fault of AC motor speed controller.
  - Please install accessories such as brake units, brake resistors in accordance with the user's instruction; otherwise it may cause AC motor speed controller fault or fire.
  - Please ensure that the screws of the terminals are firmly locked, otherwise it may cause AC motor speed controller fault.

## **1-4 Power on and Commissioning**

### **▲ Warning**

- Please ensure that the front cover is installed before the power is on. During the power transmission, please do not remove the cover.
- Please ensure that the power cables and signal cables are connected correctly, otherwise it may cause AC motor speed controller damaged.
- Please ensure all of the parameters are set correctly before running.
- Before running, please ensure machine not to damage running equipments. It is recommended to take running with idle load.
- Please provide an emergency stop switch when stop function setting is unavailable.
- Do not use electromagnetic contactor to start up and shut down AC motor speed controller, otherwise it may affect the life of AC motor speed controller

### **⚡ Danger**

- When fault restart function is set. Please do not approach equipment because the equipment may automatically restart after running stop.
- Please verify the use range of motors and machines. Exceeding their use range will cause motor and machine fault.
- Please do not change the parameter settings of AC motor speed

controller casually during running.

- Please do not touch the heat sink and brake resistor, otherwise you may get burned.
- Do not use wet hands to touch bottom plate and to operate switches and keys. Otherwise you may get an electric shock or injury.
- Please do not link or withdraw motors during AC motor speed controller running, otherwise it may cause AC motor speed controller protected or fault.

## 1-5 Check and Maintenance

### Warning

- Please ensure that the power and indicating light is off before checking and maintaining. Otherwise, you may get an electric shock.
- Before checking and maintaining, please touch a nearby metal substance with your hand to eliminate the static electricity for preventing AC motor speed controller from damage caused by static electricity.
- Please do not use Megohmmeter (insulation resistance) to test the control circuit of AC motor speed controller.

### Danger

- Only authorized professional personnel can do check, maintenance and replacement of the components, no other people are allowed.
- Please do check, maintenance and replacement of the components according to appointed methods in the user's instruction, strictly prohibit modifying by your own. If you do so, you may get an electric shock and injury or AC motor speed controller may get damaged.

---

## 1-6 Exception Processing

### Danger

- When the protection in AC motor speed controller is on, please follow the fault display of AC motor speed controller to find out causes and eliminate the fault, then reset and restart AC motor speed controller. If the fault is not eliminated. Resetting and restarting AC motor speed controller can cause AC motor speed controller s or machine fault.
- When AC motor speed controller fault takes place, please do not treat it by your own, and contact our company and our distributors.

## 1-7 Scrapping Processing

### Warning

When AC motor speed controller is scrapped, please dispose it as industrial rubbish, do not burn it up.



## Chapter 2 Product Introduction

### 2-1 Unpacking Inspection

In unpacking, please confirm the following:

- Check whether the model type of AC motor speed controller is in accordance with your order.
- Check whether AC motor speed controller is damaged and related accessories are completed.

If you find an omission or disagreement, please contact the suppliers.

### 2-2 Model Description

MODEL	HC201D5E24F
INPUT	3PH 220V 50/60Hz
OUTPUT	3PH 220V 6.0A 150% 60s
RANGE	0.1~400Hz 1.5KW

HC2 □□□□ E □□ F

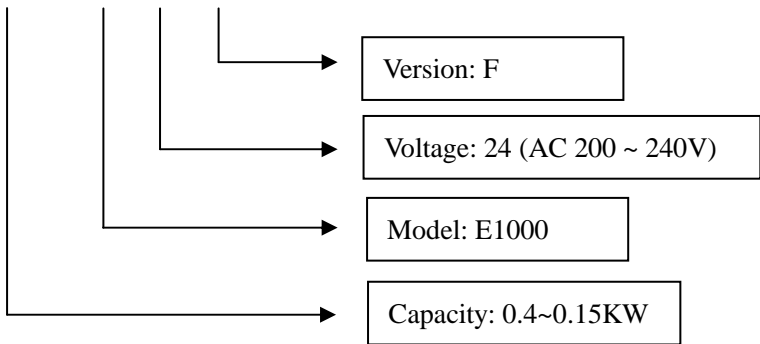

## 2-3 Product Specifications

Items		Description
Input	<b>Rated Voltage, Frequency</b>	Single/Three-phase 220V- 50/60Hz Three-phase 380V-50/60Hz
	<b>Allowable Voltage</b>	170~240V, 330~440V
Output	<b>Allowable Voltage</b>	170~240V, 330~440V
	<b>Frequency</b>	0.10~400.0Hz
<b>Control Mode</b>		V/F control
<b>Display</b>		Five-digit LED display, Indicator display; Display setup frequency, Output frequency, Output current, DC voltage, Module temperature, Running state, and fault
Control Function	<b>Frequency Setup</b>	Digital setting: 0.01 Hz. Analog setup: 0.1% of maximum output frequency
	<b>Frequency Accuracy</b>	0.1Hz
	<b>V/F Control</b>	Changeable V/F curve by setting
	<b>Torque Control</b>	Auto raising torque by loading condition; Manual increase: enable to set 0 to 20 % of raising torque
	<b>Input Terminal</b>	4 multi-function input, take 15 speed control, process, 2 sets of acceleration/deceleration
	<b>Output Terminal</b>	1 set of alarm
	<b>Time Setup</b>	0~999.9s for speed up / down
<b>Other Function</b>		Analog input 0~10V, 8 steps of multi-speed, auto stable voltage
Environment	<b>Temperature</b>	-10℃ to 40℃ (non-freezing)
	<b>Humidity</b>	Max. 95% (non-condensing)
	<b>Altitude</b>	Under 1000m
	<b>Vibration</b>	Max. 0.5G
Structure	<b>Cooling Mode</b>	Compulsory cooling
	<b>Protection Level</b>	IP 20



## 2-4 Product Models

Model	Power Output	Capacity KVA	Output current (A)	Overload capacity (60s) (A)	Applicable motor (KW)
Single/Three-phase 220V - 50/60Hz					
<b>HC200D4E24F</b>	0.4	1.0	2.5	3.75	0.4
<b>HC200D7E24F</b>	0.75	2.0	5.0	7.5	0.75
<b>HC201D5E24F</b>	1.5	2.8	7.0	10.5	1.5
<b>HC202D2E24F</b>	2.2	4.4	11	16.5	2.2
Three-phase 380V - 50/60Hz					
<b>HC200D7E48F</b>	0.75	2.2	2.7	4.05	0.75
<b>HC201D5E48F</b>	1.5	3.2	4.0	6.0	1.5
<b>HC202D2E48F</b>	2.2	4.0	5.0	7.5	2.2

## 2-5 Dimensions

Model	L	W	H	L1	W1	F	KG
<b>HC200D4E24F</b>	141.5	85	113	130.5	74	5	1
<b>HC200D7E24F</b>							
<b>HC201D5E24F</b>							
<b>HC202D2E24F</b>	151	100	111.7	139.6	8.6	5.2	1.3
<b>HC200D7E48F</b>							
<b>HC201D5E48F</b>							
<b>HC202D2E48F</b>							

Unit: cm

# Chapter 3 Wiring and Operation

## 3-1 Wiring Diagram

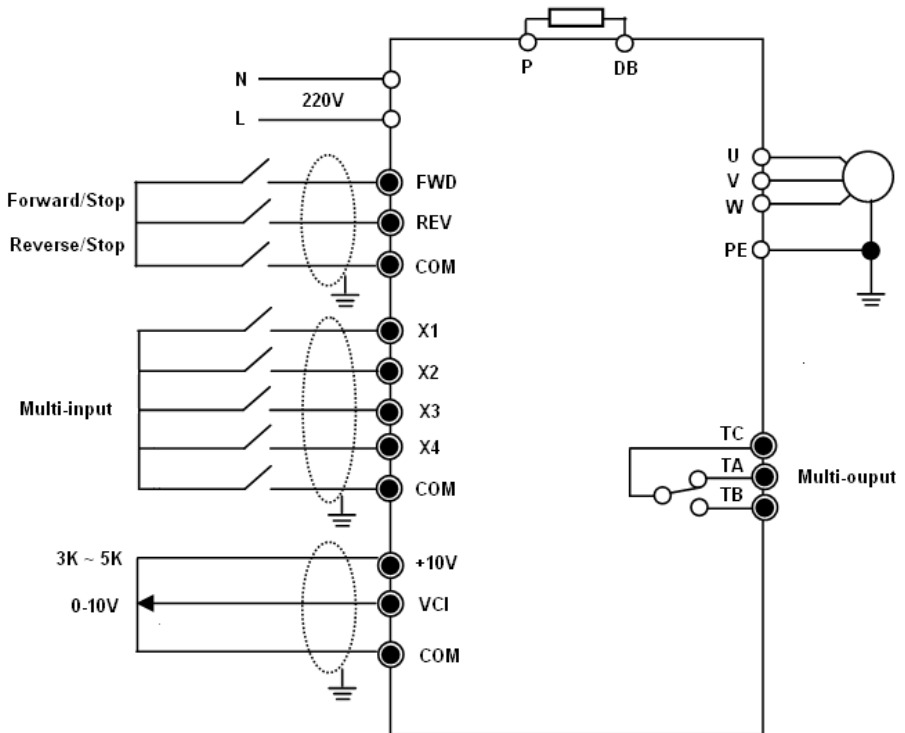

## 3-2 Display Panel

The display panel of Series E1000 consists of LED tubes, LED indicators buttons and digital elements. The outline and functions as the following:

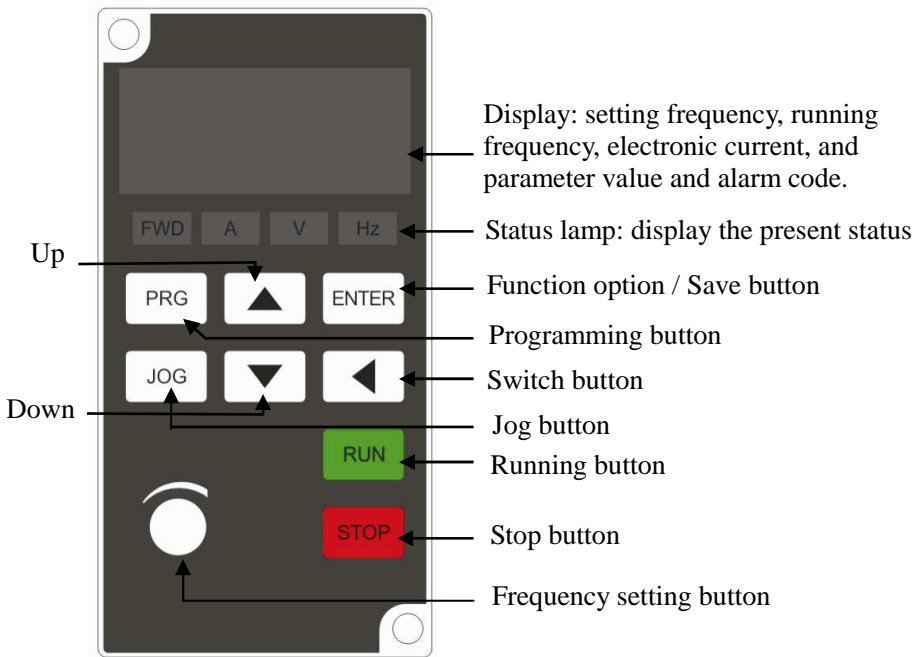

**Picture of the display panel**

### 3-3 Parameter Setting

Properly setting the parameters will be running effectively. The following is the example: 50HZ is changed into 25.00HZ.

The operation as the picture shown, pushing the shift button will switch the twinkle position for change. This button has one-way circle function.

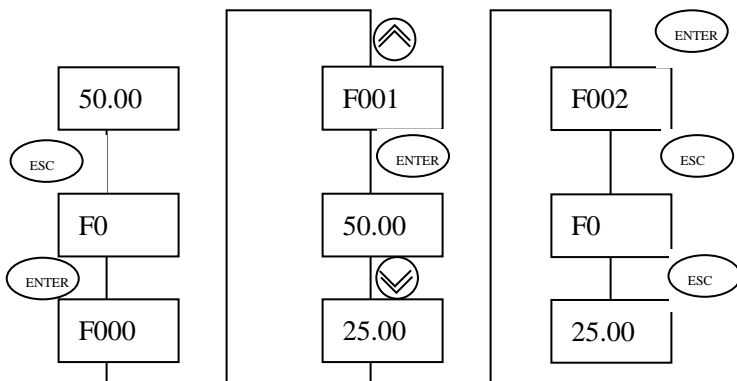

## Chapter 4 Table of Functional Parameters

### F0 group - Basic parameters

Code	Parameter	Settings	Default
F000	Frequency setup	0: Digital 1: Keyboard POT 2: Analog	0 *1
F001	Main frequency	0.0 ~ 400.0Hz	50Hz
F002	Operation setup	0: Keyboard 1: IO terminal	0
F004	Maximum running Frequency	50.0 ~ 400.0Hz	50Hz *60Hz
F005	Rated frequency of motor	50 Hz	50 Hz
F006	Rated voltage of motor	220V	220 V
F008	Voltage of torque compensation	0-30	6
F012	Acceleration time	0.1 ~ 3600s	10s *0.5s
F013	Deceleration time	0.1 ~ 3600s	10s *0.5s
F014	Upper frequency limit	0.0 ~ 400Hz	50Hz
F015	Lower frequency limit	0.0 ~ F014	0Hz

### F1 group c Tool parameters

Code	Parameter	Settings	Default
F105	Stop mode	0: Speed down 1: Coast	0
F106	Start frequency of DC braking	0 ~ 10Hz	6 Hz
F107	Start voltage of DC braking	0 ~ 15%	10%
F109	Forward /Reverse compensation time	0.0s	0s
F116	Deviation Frequency		0.0Hz
F117	Setting frequency gain		100



Code	Parameter	Settings	Default
F120	Jog frequency	0.0 ~ 10.0Hz	0.2Hz *2Hz
F121	Jog acceleration time	0.01s ~ 60.00s	1s

### F2 group – Input / Output parameters

Code	Parameter	Settings	Default
F200	Control mode	0: General 1: Knitting	0
F201	X1 terminal	1: Speed terminal 1 2: Speed terminal 2	1
F202	X2 terminal	3: Speed terminal 3 14: Instant stop (normal open)	2
F203	X3 terminal	15: Instant stop (normal close)	3 *16
F204	X4 terminal	4: Jog	4 *0
F216	Multi-speed frequency 1	0.0 ~ 400.0Hz	5Hz
F220	Multi-speed frequency 2		10Hz
F224	Multi-speed frequency 3		15Hz
F228	Multi-speed frequency 4		20Hz
F232	Multi-speed frequency 5		30Hz
F236	Multi-speed frequency 6		40Hz
F240	Multi-speed frequency 7		50Hz

### F3 group – Advanced parameters

Code	Parameter	Settings	Default
F301	Carrier frequency adjustment	0.0 ~ 12KHz	6KHz *7KHz
F306	Reverse mode	0: enable 1: disable	0
F320	Unlock parameters	0: All parameters unlocked 2: Only this group unlocked	
F321	Initialization parameters	0: No action 1: Clear fault records	

#### F4 group– Display parameters

Code	Parameter	Default
F400	Output frequency	
F401	Setup frequency	
F403	Output voltage	219
F404	Voltage of DC bus	300
F405	Input terminal signal	0
F409	Fault record 1	
F410	Fault record 2	
F411	Fault record 3	
F412	Fault record 4	

#### Example: Multi-speed

Parameter	F203 = 3	F202 = 2	F201 = 1
Terminal	X3	X2	X1
F001, F005	0	0	0
F216	0	0	1
F220	0	1	0
F224	0	1	1
F228	1	0	0
F232	1	0	1
F236	1	1	0
F244	1	1	1

#### ※ Process of setting to default (the factory setting):

Set F321 for 1 → Press “Up” for 5 seconds → Show 2 on the display  
→ Press “Enter” → Show “-----“ on the display → complete

**Note: Some default values will be the value with\***



## Chapter 5 Fault Alarm and Solution

<b>Error Code</b>	<b>Alarm</b>	<b>Possible Reason</b>	<b>Solution</b>
OC-1	Over Current in Acceleration	1) Too short acceleration time 2) Disarrangement of V/F curve 3) Restart in running the motor 4) The capacity is not suitable for the motor 5) Disarrangement of controller	1) Extend acceleration time 2) Correct V/F curve 3) Restart after running the motor 4) Select a suitable motor 5) Check the connection
OC-2	Over Current in Deceleration	1) Too short deceleration time 2) Bigger potential load or loading inertia 3) Less the capacity 4) Disarrangement of controller	1) Extend deceleration time 2) Add braking resistors 3) Select a suitable motor 4) Check the connection
OC	Over Current in Constant speed	1) Too low voltage 2) Less the capacity 3) Restart in running the motor 4) Too heavy load	1) Check the input power 2) Check the phrase 3) Select a suitable motor 4) Restart after running the motor 5) Check the connection
OE-1	Over Voltage in Running	1) Abnormal input voltage 2) Restart in running the motor	1) Check the input power 2) Restart after running the motor
OE-2	Over Voltage in deceleration	1) Too short deceleration time 2) Bigger potential load or loading inertia 3) Abnormal voltage	1) Extend deceleration time 2) Add braking resistors 3) Check the input power
OE	Over Voltage in constant speed	1) Abnormal input voltage	1) Install input voltage 2) Check the input voltage

ELT	Failed to the Capacity Module	<ol style="list-style-type: none"> <li>1) Sudden over current</li> <li>2) Short circuit of the output or grounding</li> <li>3) Bad aeration or failed the fan</li> <li>4) Failed the capacity bridge</li> </ol>	<ol style="list-style-type: none"> <li>1) Refer to error code OC</li> <li>2) Check the connection and the wire</li> <li>3) Improve aeration or replace the fan</li> </ol>
OH	Over Heat in Capacity Module	<ol style="list-style-type: none"> <li>1) Go beyond the requirement</li> <li>2) Bad aeration or failed the fan</li> <li>3) Failed to Detective circuit of temperature</li> </ol>	<ol style="list-style-type: none"> <li>1) Improve the environment</li> <li>2) Improve aeration or replace the fan</li> </ol>
OL	Over load of Motor	<ol style="list-style-type: none"> <li>1) Disarrangement of V/F curve</li> <li>2) Too low voltage</li> <li>3) Run with low speed and high torque for a long time</li> <li>4) Set improper over loading coefficient of the motor</li> <li>5) The motor is blocked or too high torque</li> </ol>	<ol style="list-style-type: none"> <li>1) Correct V/F curve</li> <li>2) Check the input power</li> <li>3) Select a specialized inverter</li> <li>4) Check the set parameters</li> <li>5) Select a suitable motor</li> <li>6) Check the connection</li> </ol>
EMS	Failed to the External	<ol style="list-style-type: none"> <li>1) Failed to terminals of the external equipment</li> </ol>	<ol style="list-style-type: none"> <li>1) Check the terminals</li> </ol>
CPUE	Magnetic disturbance	<ol style="list-style-type: none"> <li>1) Taking serious disturbance</li> </ol>	<ol style="list-style-type: none"> <li>1) Push STOP/RESET button</li> </ol>
-.E.r	Failed to EPROM	<ol style="list-style-type: none"> <li>1) Taking serious disturbance of EPROM in reading / writing</li> <li>2) Failed EPROM</li> </ol>	<ol style="list-style-type: none"> <li>1) Push STOP/RESET button</li> </ol>
STOP	Emergency stop	<ol style="list-style-type: none"> <li>1) locked the emergency stop</li> </ol>	<ol style="list-style-type: none"> <li>1) Push STOP/RESET button twice to unlock the emergency stop</li> </ol>